

LIMIT UNLESS OTHERWISE NOTED  
 FRACT.±1/16" DEC.DIM.±.010 ANGULAR±1°

THE DRAWING IS LOANED WITH THE EXPRESSED AGREEMENT THAT THE DRAWING AND INFORMATION THEREIN CONTAINED ARE THE PROPERTY OF ELECTRIC POWER DOOR AND WILL NOT BE REPRODUCED OR COPIED IN WHOLE OR IN PART NOR USED FOR THE FABRICATION OR CONSTRUCTION OF MATERIALS EXCEPT UPON THE WRITTEN PERMISSION OF ELECTRIC POWER DOOR FIRST OBTAINED AND SPECIFIC AS TO USE. THE ACCEPTANCE OF THIS DRAWING WILL BE CONSTRUED AS THE ACCEPTANCE OF THE FOREGOING AGREEMENT.

THIS DRAWING CONTAINS FIELD INSTALLED PARTS & INSTALLATION DETAILS

NOTE:  
 1. PAINT ALL EXPOSED STEEL PER SPECIFICATIONS AS SHOWN ON DRAWING NUMBER 1.0.

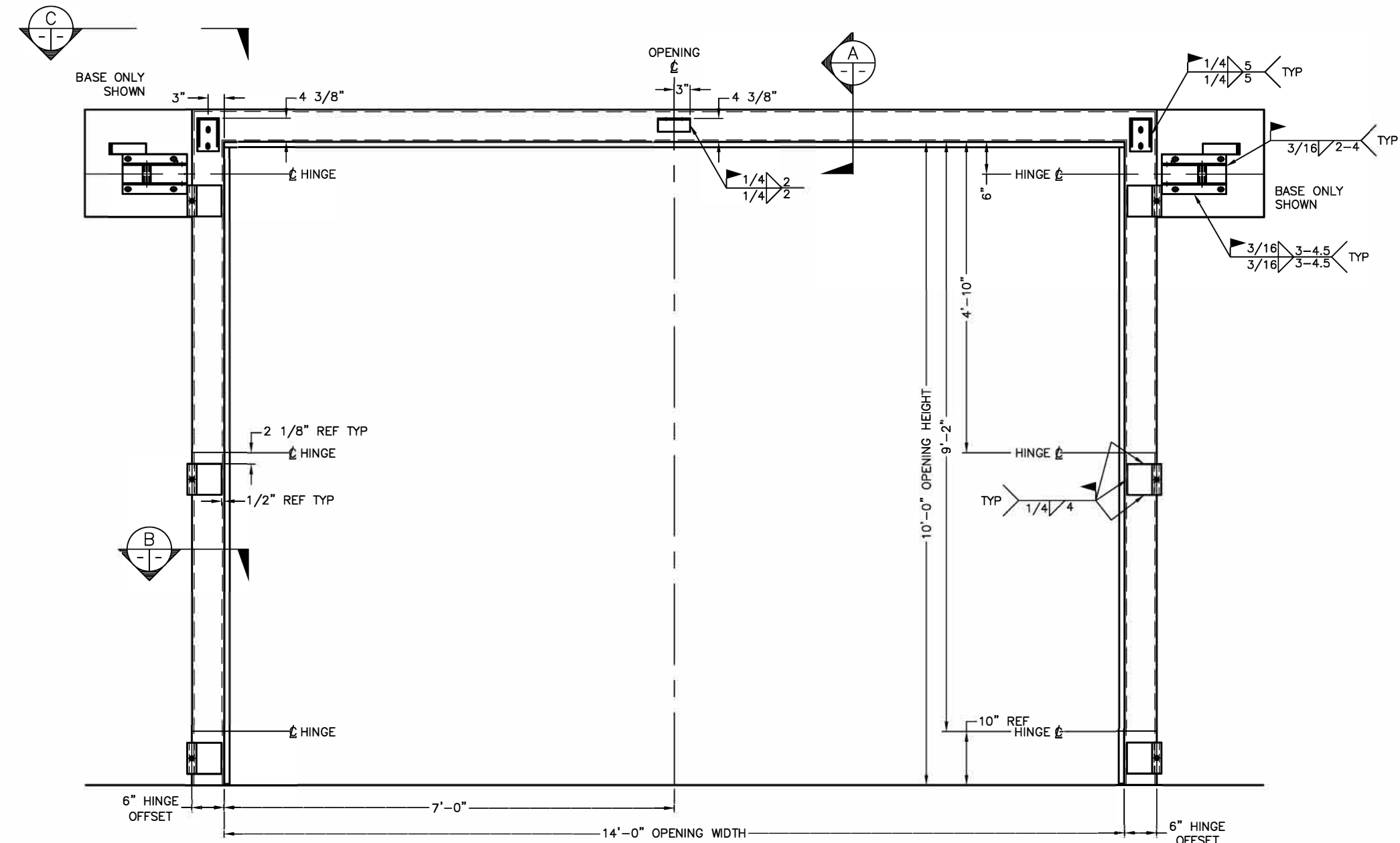
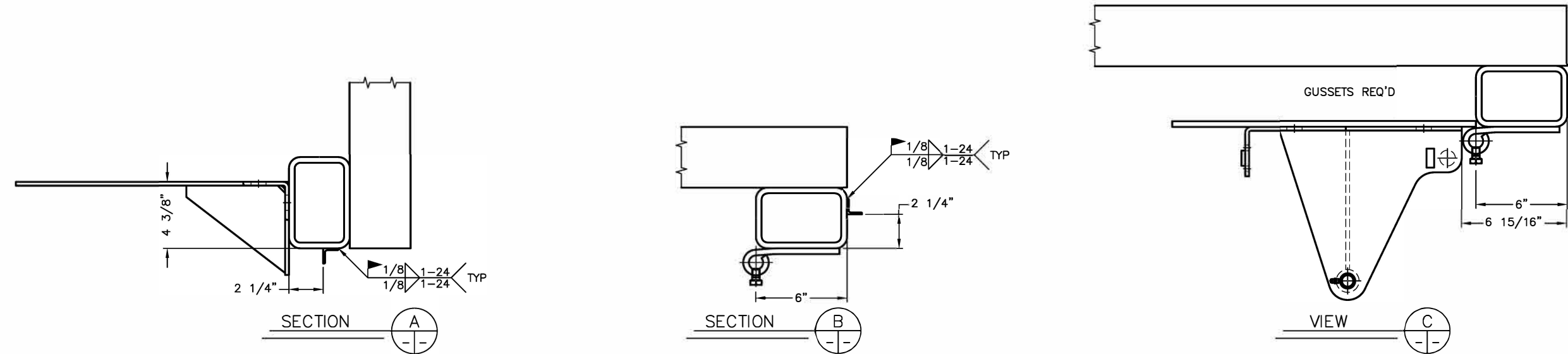

**HARDWARE PLACEMENT AND WELDING**  
 HINGE SIDE ELEVATION  
 6" HINGE OFFSET, TUBE STEEL FRAME

3			
2			
1	RELEASED FOR APPROVAL		
REV.	DESCRIPTION	DATE	DR. BY:

Q.C. REVIEWED BY:  
 DRAWN BY: DATE: CHKD:

**HARDWARE WELDING DETAILS**  
**MODEL 46 FOUR FOLD DOOR**  
**HYDRAULIC OPERATOR**  
**6" OFFSET, TUBE STEEL FRAME**

JOB NAME:  
 CUSTOMER:  
 ARCHITECT:  
 JOB SITE:

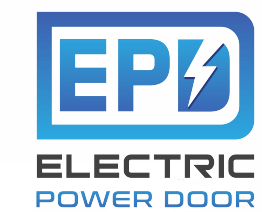

522 West 27th Street, Hibbing, Minnesota 55746  
 (218) 263-8366

SCALE	CUST. ORDER NO.	JOB NO.	Drawing NO.
NTS			4.1

ACAD STORAGE NO.