

LIMIT UNLESS OTHERWISE NOTED
 FRACT.±1/16" DEC.DIM.±.010 ANGULAR±1°

THE DRAWING IS LOANED WITH THE EXPRESSED AGREEMENT THAT THE DRAWING AND INFORMATION THEREIN CONTAINED ARE THE PROPERTY OF ELECTRIC POWER DOOR AND WILL NOT BE REPRODUCED OR COPIED IN WHOLE OR IN PART NOR USED FOR THE FABRICATION OR CONSTRUCTION OF MATERIALS EXCEPT UPON THE WRITTEN PERMISSION OF ELECTRIC POWER DOOR FIRST OBTAINED AND SPECIFIC AS TO USE. THE ACCEPTANCE OF THIS DRAWING WILL BE CONSTRUED AS THE ACCEPTANCE OF THE FOREGOING AGREEMENT.

THIS DRAWING CONTAINS FIELD INSTALLED PARTS & INSTALLATION DETAILS

NOTE:

1. CORE TO BE FILLED WITH 3/8"Ø MAX. SIZE AGGREGATE WITH 3,000 PSI CONCRETE WITH 7" TO 9" SLUMP.
2. FILL 1 BLOCK BEYOND THE STEEL PLATE AND 2 ROWS ABOVE & BELOW ALL STEEL.
3. DO NOT HAVE AN ANCHOR CLOSER THAN 3" TO EDGE OF CONCRETE.
4. CONCRETE TO CURE A MINIMUM OF 7 DAYS BEFORE ANCHORING.
5. ANCHOR SYSTEM MUST BE DESIGNED BY OTHERS TO RESIST THE LOADING SHOWN ON DRAWING.
6. FLANGE WIDTHS & ANGLE SIZES ARE MINIMUMS REQUIRED. LARGER SIZES MAY BE USED. PLATES ARE A36 STEEL. ALL FRAME STEEL NOT BY EPD.

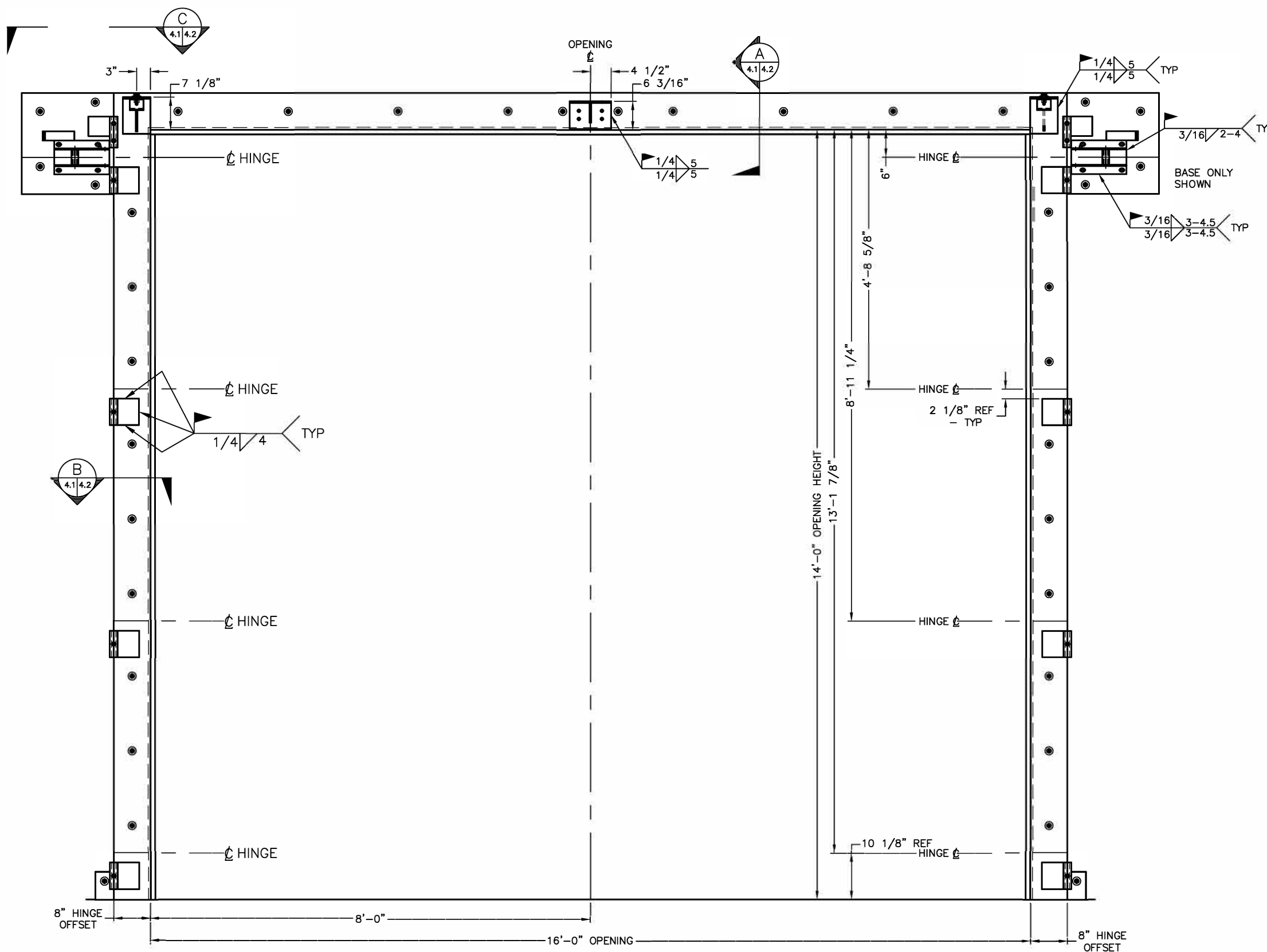

HARDWARE PLACEMENT AND WELDING
 HINGE SIDE ELEVATION
 8" HINGE OFFSET, GROUT FILLED BLOCK, STEEL FRAME

3			
2			
1	RELEASED FOR APPROVAL		
REV.	DESCRIPTION	DATE	DR. BY:

Q.C. REVIEWED BY:
 DRAWN BY: DATE: CHKD:

HARDWARE WELDING DETAILS
 MODEL 46 FOUR FOLD DOOR
 HYDRAULIC OPERATOR, 8" OFFSET,
 GROUT FILLED BLOCK, STEEL FRAME

JOB NAME:
 CUSTOMER:
 ARCHITECT:
 JOB SITE:



**ELECTRIC
 POWER DOOR**

522 West 27th Street, Hibbing, Minnesota 55746
 (218)263-8366

SCALE	CUST. ORDER NO.	JOB NO.	Drawing NO.
NTS			4.1

ACAD STORAGE NO.

LIMIT UNLESS OTHERWISE NOTED
 FRACT.±1/16" DEC.DIM.±.010 ANGULAR±1'

THE DRAWING IS LOANED WITH THE EXPRESSED AGREEMENT THAT THE DRAWING AND INFORMATION THEREIN CONTAINED ARE THE PROPERTY OF ELECTRIC POWER DOOR AND WILL NOT BE REPRODUCED OR COPIED IN WHOLE OR IN PART NOR USED FOR THE FABRICATION OR CONSTRUCTION OF MATERIALS EXCEPT UPON THE WRITTEN PERMISSION OF ELECTRIC POWER DOOR FIRST OBTAINED AND SPECIFIC AS TO USE. THE ACCEPTANCE OF THIS DRAWING WILL BE CONSTRUED AS THE ACCEPTANCE OF THE FOREGOING AGREEMENT.

THIS DRAWING CONTAINS FIELD INSTALLED PARTS & INSTALLATION DETAILS

- NOTE:
1. CORE TO BE FILLED WITH 3/8"Ø MAX. SIZE AGGREGATE WITH 3,000 PSI CONCRETE WITH 7" TO 9" SLUMP.
 2. FILL 1 BLOCK BEYOND THE STEEL PLATE AND 2 ROWS ABOVE & BELOW ALL STEEL.
 3. DO NOT HAVE AN ANCHOR CLOSER THAN 3" TO EDGE OF CONCRETE.
 4. CONCRETE TO CURE A MINIMUM OF 7 DAYS BEFORE ANCHORING.
 5. ANCHOR SYSTEM MUST BE DESIGNED BY OTHERS TO RESIST THE LOADING SHOWN ON DRAWING.
 6. FLANGE WIDTHS & ANGLE SIZES ARE MINIMUMS REQUIRED. LARGER SIZES MAY BE USED. PLATES ARE A36 STEEL. ALL FRAME STEEL NOT BY EPD.

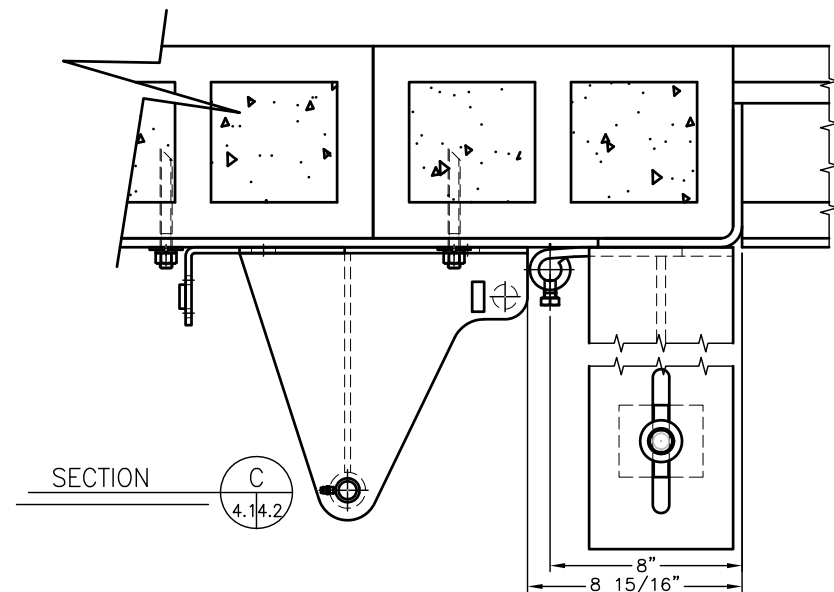
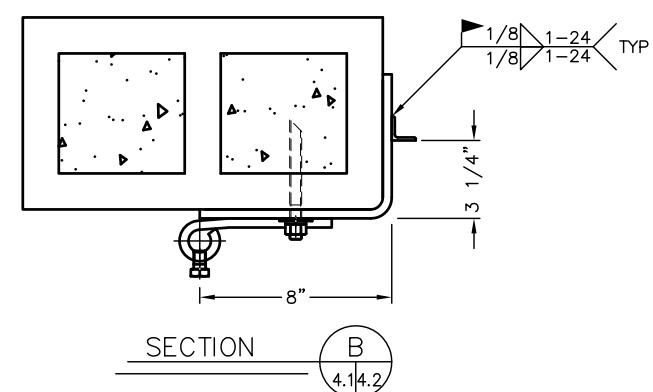
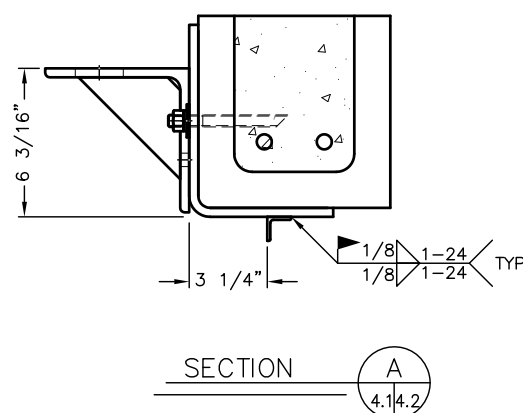

3			
2			
1	RELEASED FOR APPROVAL		
REV.	DESCRIPTION	DATE	DR. BY:

Q.C. REVIEWED BY:
 DRAWN BY: DATE: CHKD:

FRAME TEMPLATE SECTIONS
 MODEL 46 FOUR FOLD DOOR
 HYDRAULIC OPERATOR, 8" OFFSET,
 GROUT FILLED BLOCK, STEEL FRAME

JOB NAME:

CUSTOMER:

ARCHITECT:

JOB SITE:



Engineering in motion

522 West 27th Street, Hibbing, Minnesota 55746
 (218)263-8366

SCALE	CUST. ORDER NO.	JOB NO.	Drawing NO.
NTS			4.2
ACAD STORAGE NO.			