

LIMIT UNLESS OTHERWISE NOTED
 FRACT.±1/16" DEC.DIM.±.010 ANGULAR±1°

THE DRAWING IS LOANED WITH THE EXPRESSED AGREEMENT THAT THE DRAWING AND INFORMATION THEREIN CONTAINED ARE THE PROPERTY OF ELECTRIC POWER DOOR AND WILL NOT BE REPRODUCED OR COPIED IN WHOLE OR IN PART NOR USED FOR THE FABRICATION OR CONSTRUCTION OF MATERIALS EXCEPT UPON THE WRITTEN PERMISSION OF ELECTRIC POWER DOOR FIRST OBTAINED AND SPECIFIC AS TO USE. THE ACCEPTANCE OF THIS DRAWING WILL BE CONSTRUED AS THE ACCEPTANCE OF THE FOREGOING AGREEMENT.

THIS DRAWING CONTAINS FIELD INSTALLED PARTS & INSTALLATION DETAILS

NOTE:
 1. DIMENSIONS GIVEN ARE REFERENCE ONLY, AS THE DOOR MUST BE MOUNTED PLUMB REGARDLESS OF JAMB CONDITIONS.
 2. ALL WELDING TO BE PER AWS D1.1.

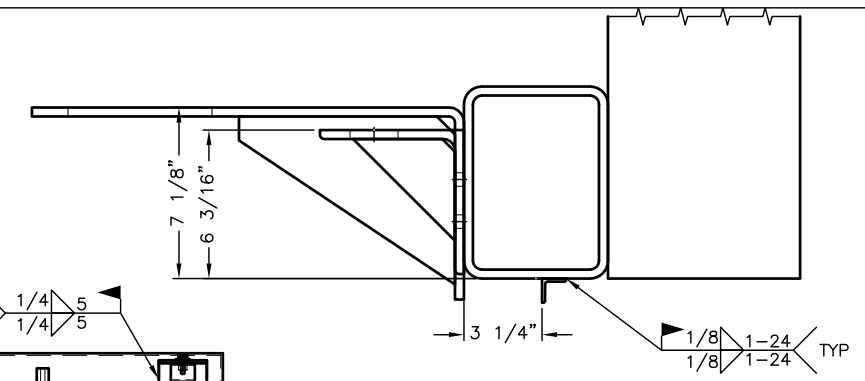
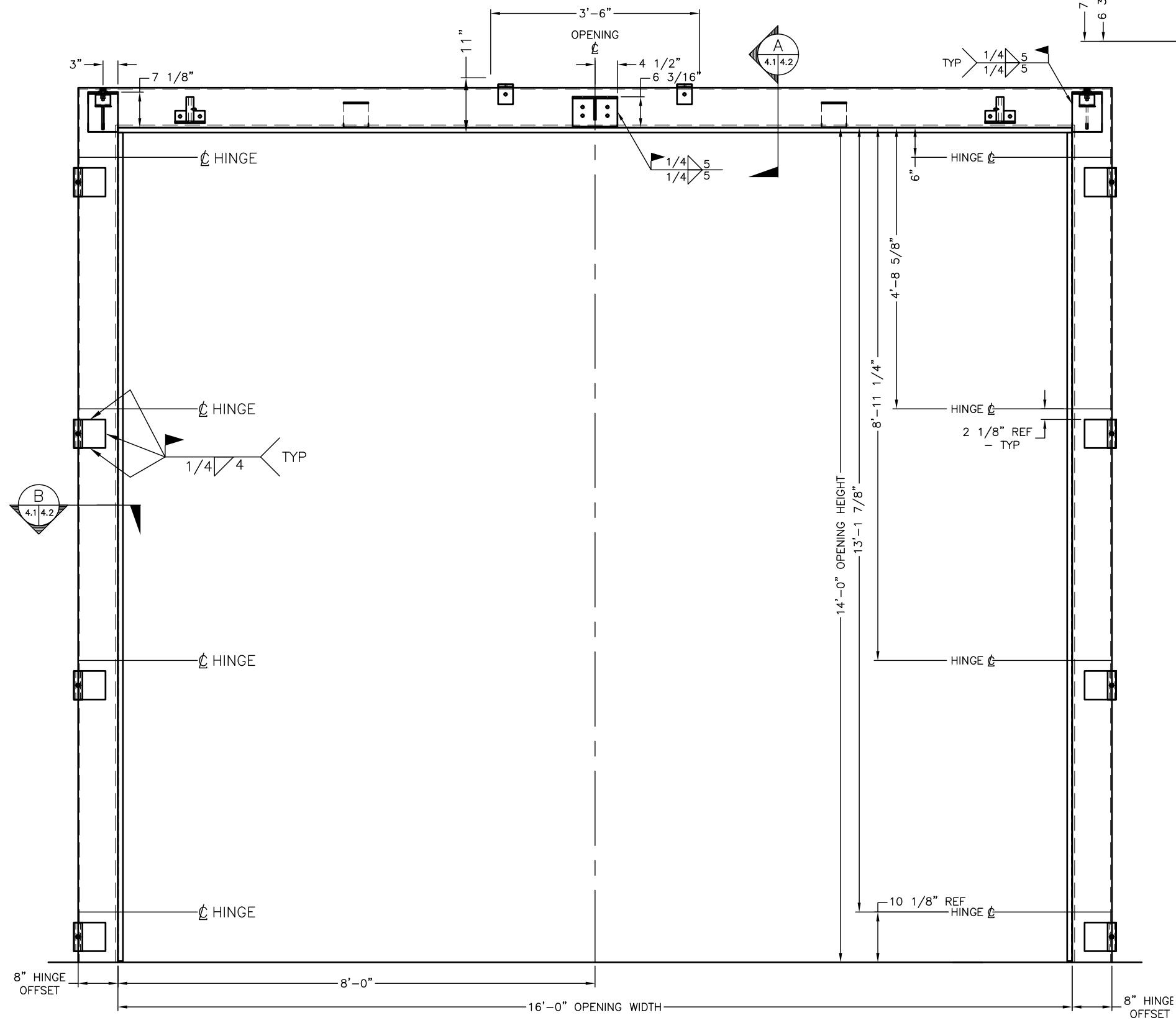

SECTION A
 4.14.2

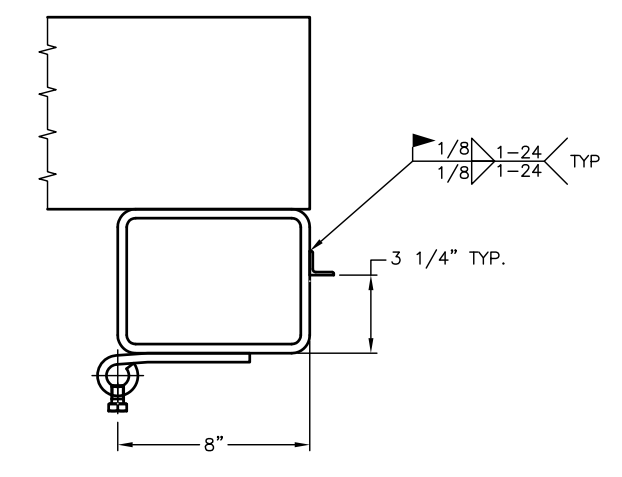

SECTION B
 4.14.2

HARDWARE PLACEMENT AND WELDING
 HINGE SIDE ELEVATION
 8" HINGE OFFSET, TUBE STEEL FRAME

3			
2			
1			
REV.	DESCRIPTION	DATE	DR. BY:

Q.C. REVIEWED BY:
 DRAWN BY: DATE: CHKD:
 FRAME TEMPLATE AND DETAILS
 ELECTRIC FOUR FOLD DOOR
 8" OFFSET, TUBE STEEL FRAME
 JOB NAME:
 CUSTOMER:
 ARCHITECT:
 JOB SITE:

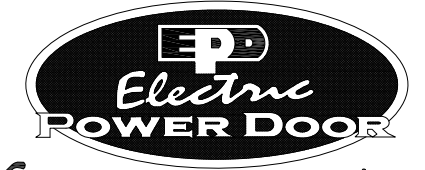

Engineering in motion
 522 West 27th Street, Hibbing, Minnesota 55746
 (218)263-8366

SCALE	CUST. ORDER NO.	JOB NO.	Drawing NO.
NTS			
ACAD STORAGE NO.			